

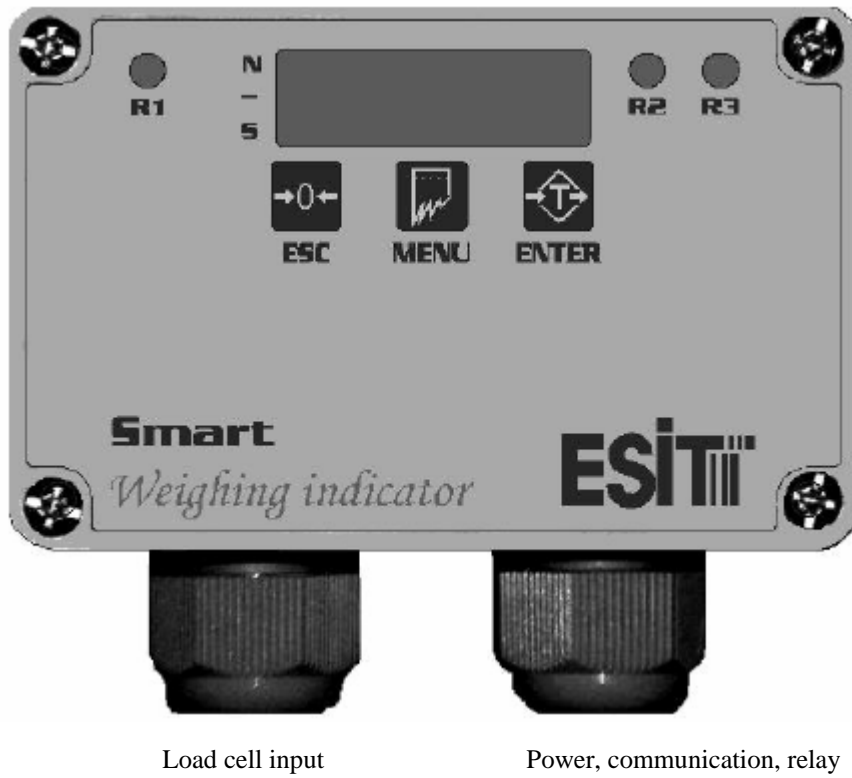

**WEIGHT INDICATOR
SMART
User manual**



GENERAL DESCRIPTION



Key

Function



Zerolise display value or go back one level in menu system.



Enable/disable tare function and select/confirm a menu



Navigate (MENU access key)

ANNUNCIATORS

No-motion: Lights when there is no motion on the platform in the range of $\pm 2e$ within 2seconds. (e: Display resolution value)



Center of zero: Lights when displayed weight is zero and the internal count is less than 1/4d.



Net: Lights when tare function is enabled.



Minus: Lights when displayed value is negative and exceeded 3 digits. Otherwise minus '-' sign can be monitored on the 4. digit.





INDICATOR CONNECTIONS

On the printed circuit board of the indicator, the connections are shown below assigning the leftmost terminal with terminal #1. For further information please read 'Connection and Hardware selections' section.

1	2	3	4	5	6	7	8	9	10	11	12	13	14	15	16	17	18	19	20	21
+ Excitation	+LC 1 input	-LC 1 input	***	***	***	- Excitation	SHIELD	+DAC	-DAC	+V (9-36V)	0V GND	Tx / B	Rx / A	SHIELD	RL 1(n.o.)	RL 1(com)	RL 2(n.o.)	RL 2(com)	RL 3(n.o.)	RL 3(com)

ACTIVATING TARE WITH KEY

Manual tare function could be enabled with  key in no-motion situation. With enabled tare display would be zeroed and net annunciator will lit on.

To disable the tare function, press  key in a motionless situation. As a consequence, net annunciator will lit off.



ZEROING THE DISPLAY WITH KEY

To zero the platform with  key, internal count would be less than 1/4e and platform would be motionless.

When  key pressed, display will be zeroed and center of zero annunciator will lit on.



MENU SYSTEM

Press  key to access and navigate in the menu system.

IDENTITY MENU: To monitor the serial number and version information



DISPLAY MENU: To adjust display resolution or step value (e), decimal point and weighing capacity



CALIBRATION MENU: To perform zero and load calibrations.



OUTPUT1 (RELAY#1) MENU: Set point, direction, hysteresis, and time delay for Relay#1 are entered.



OUTPUT2 (RELAY#2) MENU: Set point, direction, hysteresis, and time delay for Relay#2 are entered.



OUTPUT3 (RELAY#3) MENU: Set point, direction, hysteresis, and time delay for Relay#3 are entered.



ANALOG OUTPUT (DAC) MENU: DAC low output, DAC high output and DAC maximum output value can be set.



COMMUNICATION PARAMETERS MENU:

Communication mode, scale number, and communication format can be adjusted.



INDICATOR IDENTITY INFORMATIONS

By using this menu indicator serial number and version info can be monitored.

MONITORING SERIAL NUMBER

- (1) Press the navigation  key until 'Identity' menu appears



- (2) Press  key to confirm the menu

- (3) Press the navigation  key until 'Serial number' menu appears

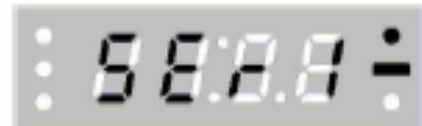

- (4) Press  key to confirm the menu

- (5) Serial number of the indicator can be monitored on the display

- (6) Press  key to quit menu system until normal operation appears

MONITORING VERSION INFO

- (1) Press the navigation  key until 'Identity' menu appears

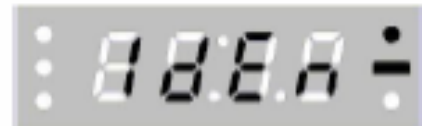

- (2) Press  key to confirm the menu

- (3) Press the navigation  key until 'version info' menu appears



- (4) Press  key to confirm the menu

- (5) Version info of the indicator can be monitored on the display

- (6) Press  key to quit menu system until normal operation appears

DISPLAY SETTINGS

ATTENTION: JP13 connection must be open-circuited in order to save the changes on display menu settings. Otherwise all settings in this menu can only be displayed just for information and any attempt to save the settings generates special error code as a consequence.

DECIMAL POINT SETTING

When the display resolution needs decimal point for fractional values, it is possible to show it on the display.

- (1) Press the navigation  key until 'Display' menu appears



- (2) Press  key to confirm the menu

- (3) Press the navigation  key until 'Decimal Point' menu appears



- (4) Press  key to confirm the menu

- (5) Scroll with the navigation key  until you find the decimal point you are looking for

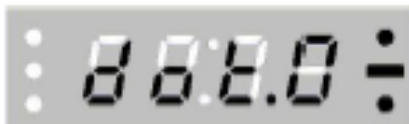

Implies

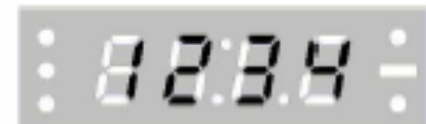



Implies



Implies





- (6) Press  key to store changes
(7) Press  key to quit menu system until normal operation appears

STEP VALUE (RESOLUTION) SETTING

- (1) Press the navigation  key until 'Display' menu appears



- (2) Press  key to confirm the menu

- (3) Press the navigation  key until 'Step value' menu appears

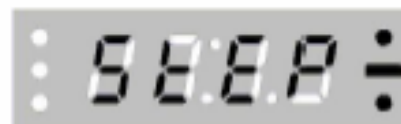

- (4) Press  key to confirm the menu

- (5) Scroll with the navigation key  until you find the step value you are looking for



Implies $e = 1$

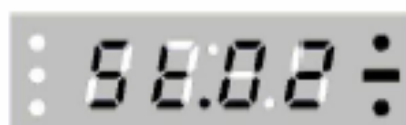

Implies $e = 2$

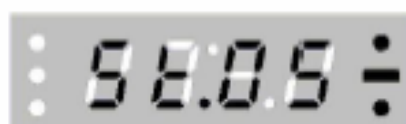

Implies $e = 5$

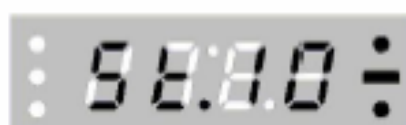

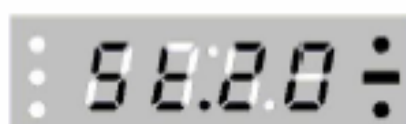

Implies $e = 10$

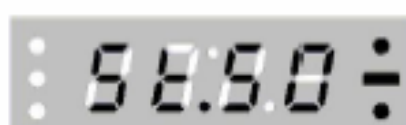

Implies $e = 20$



Implies $e = 50$

- (6) Press  key to store changes
- (7) Press  key to quit menu system until normal operation appears

WEIGHING CAPACITY SETTING

This value determines maximum weighing capacity on the indicator display. If the weight value on the platform exceeds $MAX \pm (9e)$, indicator will produce related error codes.

- (1) Press the navigation  key until 'Display' menu appears

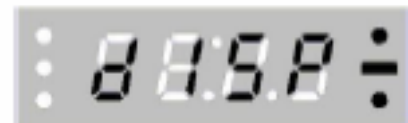

- (2) Press  key to confirm the menu



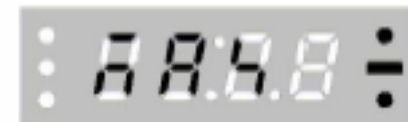

- (3) Press the navigation  key until 'Weighing Capacity' menu appears

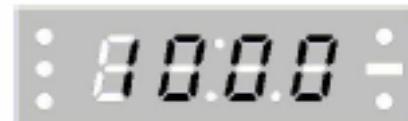

- (4) Press  key to confirm the menu

- (5) The last stored weighing capacity is displayed while thousands' place is blinking



- (6) Blinking digit value can be incremented with  key, blinking digit can be changed with  key
- (7) Press  key to store weighing capacity
- (8) Press  key to quit menu system until normal operation appears

WEIGHT CALIBRATION

ATTENTION: JP13 connection must be open-circuited indicator. Any attempt to confirm the 'calibration' code as a consequence.

ZERO CALIBRATION

(1) Press the navigation  key until 'Calibration' menu appears.

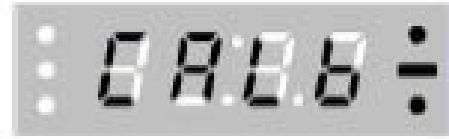

(2) Press  key to confirm the menu.

(3) 'Zero calibration' menu blinks for a short time and starts to monitor internal count besides blinking rightmost leds on the display



(4) After the platform is emptied, press  to calibrate

(5) After 'Zero Calibration' is completed, indicator will automatically go into 'Load Calibration' and 'LOAD' expression blinks for a short while. Then, internal count can be displayed with rightmost leds continuously lighting.



(6) While internal count is monitored, by pressing  key again zero calibration can be performed. Press  key to quit menu system until normal operation (weighing mode) appears.

LOAD CALIBRATION

(1) Press the navigation  key until 'Calibration' menu appears.



(2) Press  key to confirm the menu.



(3) 'LOAD' expression blinks for a short while and starts to monitor internal count value. However the leds on the rightmost part of the display not blink like in zero calibration.



(4) While internal count is monitored, by pressing  key again zero calibration can be performed.

Place reference weight and press  key afterwards motionless is achieved.

NOTE: IT IS ADVISED TO USE AT LEAST HALF OF THE WEIGHING CAPACACITY AS A REFERENCE WEIGHT

(5) The zeros are displayed while thousands' place is blinking. Blinking digit value can be incremented with  key, blinking digit can be changed with  key.



(6) Press  key in order to complete the calibration and store new calibration value on the display.

(7) Indicator automatically resets itself and starts in normal operation according to the new calibration settings.



RELAY SETTINGS

When relay contacts are closed, the pertaining annunciator leds on the indicator (R1, R2 and R3) will lit on.

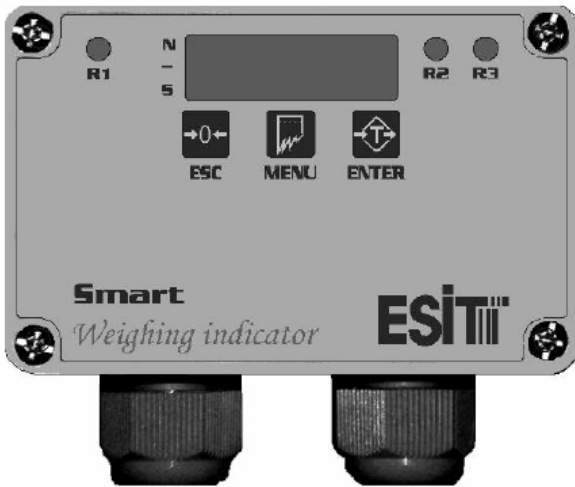

The relays can be activated both in '+' and '-' directions. For example; If 1.relay set point is set to 1000 and direction is implying upper range of 1000, for display values below -1000 relay#1 contacts will be activated or in other words "closed"

For all menu and submenus related with first relay, the leftmost leds on the display will lit on as follows



For all menu and submenus related with second relay, the leftmost leds on the display will lit on as follows



For all menu and submenus related with third relay, the leftmost leds on the display will lit on as follows



RELAY #1 SETTINGS

RELAY #1 SET POINT SETTING

(1) Press the navigation  key until '1. Relay' menu appears



(2) Press  key to confirm the menu



(3) Press the navigation  key until 'First Relay Set Point' menu appears



(4) Press  key to confirm the menu

(5) The last stored first relay set point is displayed while thousands' place is blinking



(6) Blinking digit value can be incremented with  key, blinking digit can be changed with  key

(7) Press  key to store first relay set point

(8) Press  key to quit menu system until normal operation appears

RELAY #1 SET DIRECTION SETTING

(1) Press the navigation  key until '1. Relay' menu appears



(2) Press  key to confirm the menu

(3) Press the navigation  key until 'First Relay Set Direction' menu appears

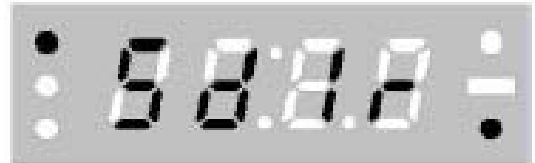

(4) Press  key to confirm the menu

(5) The last stored first relay set direction is displayed



(6) Scroll with the navigation  key until you find the set direction you are looking for



Implies Relay contacts are closed under the set point



Implies Relay contacts are closed above the set point

(7) Press  key to store first relay set direction

(8) Press  key to quit menu system until normal operation appears

RELAY #1 HYSTERISIS SETTING

Hysterisis can be defined as the difference between opening and closing thresholds of the relay contacts.

(1) Press the navigation  key until '1. Relay' menu appears



(2) Press  key to confirm the menu



(3) Press the navigation  key until 'First Relay Hysterisis Amount' menu appears





(4) Press  key to confirm the menu

(5) The last stored first relay hysterisis amount is displayed while hundreds' place is blinking



(6) Blinking digit value can be incremented with  key, blinking digit can be changed with  key

(7) Press  key to store first relay hysterisis amount

(8) Press  key to quit menu system until normal operation appears

NOTE: Hysterisis range is from 0 to 255.

RELAY #1 DELAY TIME SETTING

Setting of relays can be postponed up to 9 seconds. This setting can be performed with 'delay time' menu with 1 second intervals from 0 seconds to 9 seconds.

(1) Press the navigation  key until '1. Relay' menu appears



(2) Press  key to confirm the menu

(3) Press the navigation  key until 'First Relay Delay Time' menu appears



(4) Press  key to confirm the menu

(5) Saved first relay delay time is displayed. Scroll with the navigation  key until you find the delay time you are looking for.



Implies 0 seconds delay (no delay)



Implies 9 seconds delay

(6) Press  key to store first relay delay time

(7) Press  key to quit menu system until normal operation appears

ANALOG OUTPUT (DAC) SETTINGS

ANALOG OUTPUT CALIBRATION

In order to use SMART indicators with voltage or current controlled automation systems, the indicator's analog output must be calibrated in a correct manner.

Voltage (0-5V) or current (0-20mA) mode selection must be done prior to calibration. For analog output mode selection please read 'Connection and Hardware selections' section.

LVAL \equiv DAC LOW OUTPUT VALUE

HVAL \equiv DAC HIGH OUTPUT VALUE

DMAX \equiv DAC MAXIMUM OUTPUT VALUE

$$\text{Analog output value} = \text{LVAL} + \frac{[(\text{HVAL} - \text{LVAL}) \times \text{Display value}]}{\text{DMAX}} \quad \text{for } \text{HVAL} > \text{LVAL}$$

$$\text{Analog output value} = \text{LVAL} - \frac{[(\text{HVAL} - \text{LVAL}) \times \text{Display value}]}{\text{DMAX}} \quad \text{for } \text{LVAL} > \text{HVAL}$$

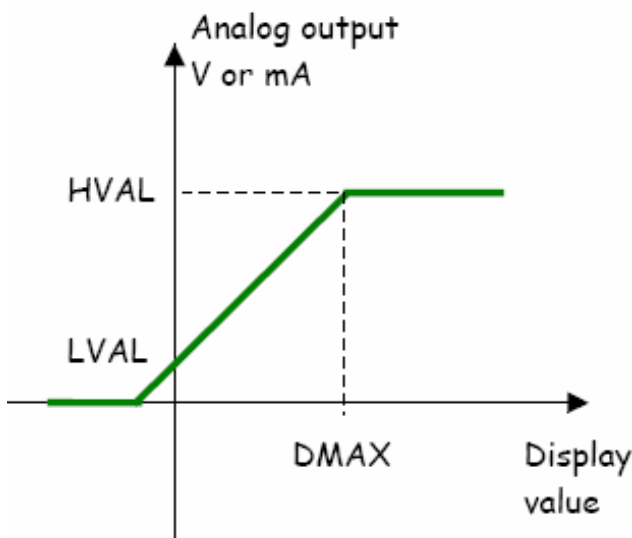

if $\text{HVAL} > \text{LVAL}$

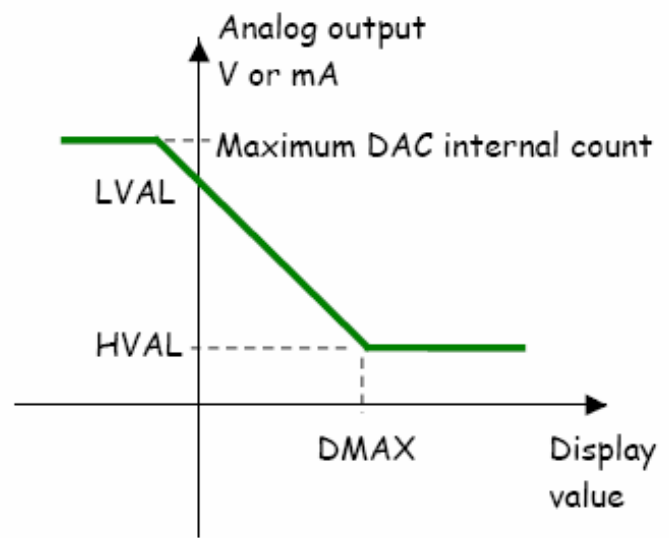

if $\text{LVAL} > \text{HVAL}$

NOTE: Maximum DAC internal count is 4095.

DAC LOW OUTPUT VALUE (LVAL) SETTING

It implies the analog output value for zero display value

- (1) Press the navigation  key until 'DAC' menu appears



- (2) Press  key to confirm the menu

- (3) Press the navigation  key until 'DAC low output (LVAL) value' menu appears







- (4) Press  key to confirm the menu

- (5) The last stored LVAL value is displayed while thousands' place is blinking



NOT: ANALOG OUTPUT CAN BE OBSERVED WHILE CHANGING LVAL VALUE.

- (6) Blinking digit value can be incremented with  key, blinking digit can be changed with  key
- (7) Press  key to store DAC low output (LVAL) value
- (8) Press  key to quit menu system until normal operation appears

DAC HIGH OUTPUT VALUE (HVAL) SETTING

It implies the analog output value for DAC maximum output (DMAX) value

- (1) Press the navigation  key until 'DAC' menu appears



- (2) Press  key to confirm the menu

- (3) Press the navigation  key until 'DAC high output (HVAL) value' menu appears





- (4) Press  key to confirm the menu

- (5) The last stored HVAL value is displayed while thousands' place is blinking



NOT: ANALOG OUTPUT CAN BE OBSERVED WHILE CHANGING HVAL VALUE.

- (6) Blinking digit value can be incremented with  key, blinking digit can be changed with  key

- (7) Press  key to store DAC high output (HVAL) value

- (8) Press  key to quit menu system until normal operation appears

DAC MAXIMUM OUTPUT VALUE (DMAX) SETTING

This display value corresponds to the DAC high output value.

- (1) Press the navigation  key until 'DAC' menu appears



- (2) Press  key to confirm the menu



- (3) Press the navigation  key until 'DAC maximum output (DMAX) value' menu appears

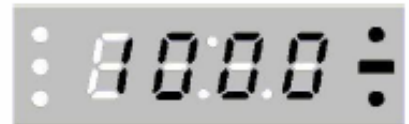

- (4) Press  key to confirm the menu

- (5) The last stored DMAX value is displayed while thousands' place is blinking



- (6) Blinking digit value can be incremented with  key, blinking digit can be changed with  key

- (7) Press  key to store DAC maximum output (DMAX) value

- (8) Press  key to quit menu system until normal operation appears

COMMUNICATION SETTINGS

COMMUNICATION MODE SETTING

- (1) Press the navigation  key until 'Communication' menu appears



- (2) Press  key to confirm the menu

- (3) Press the navigation  key until 'Communication Mode' menu appears



- (4) Press  key to confirm the menu

- (5) Scroll with the navigation  key until you find the communication mode you are looking for



NO COMMUNICATION



CONTINUOUS TRANSMISSION OF 4
DIGIT WEIGHT VALUE



(NO COMMUNICATION)



ADDRESSED COMMUNICATION

- (6) Press  key to store communication mode

- (7) Press  key to quit menu system until normal operation appears

Notes for MODE 3 communication:

The transmission of weight value is performed when the indicator realizes the code from the other side. By this way more than one indicator can be connected to the same communication line. The data format is the same as MODE 1.

For a PC to communicate with more than one indicator, this parameter should be MODE 3, and the communication hardware should be RS-485.

SCALE ADDRESS SETTING

ONLY AVAILABLE IN COMMUNICATION MODE3.

- (1) Press the navigation  key until 'Communication' menu appears



- (2) Press  key to confirm the menu

- (3) Press the navigation  key until 'Scale Address' menu appears





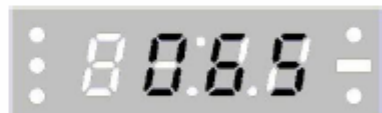

- (4) Press  key to confirm the menu

- (5) The last stored scale address is displayed while hundreds' place is blinking.



065 = hex41= "A"

NOTE: **SCALE ADDRESS RANGE IS FROM 0 TO 255**

- (6) Blinking digit value can be incremented with  key, blinking digit can be changed with  key
- (7) Press  key to store scale address
- (8) Press  key to quit menu system until normal operation appears

COMMUNICATION PARITY SETTING

- (1) Press the navigation  key until 'Communication' menu appears



- (2) Press  key to confirm the menu

- (3) Press the navigation  key until 'Communication Parity' menu appears



- (4) Press  key to confirm the menu

- (5) Scroll with the navigation  key until you find the communication parity you are looking for



Implies NO PARITY



Implies EVEN PARITY



Implies ODD PARITY

- (6) Press  key to store communication parity setting

- (7) Press  key to quit menu system until normal operation appears

COMMUNICATION SPEED (BAUD RATE) SETTING

The number of communication bits sent per second is called BAUDRATE. For SMART indicators, the selectable values are 1200, 2400, and 4800.

- (1) Press the navigation  key until 'Communication' menu appears



- (2) Press  key to confirm the menu

- (3) Press the navigation  key until 'Baud Rate' menu appears



- (4) Press  key to confirm the menu

- (5) Scroll with the navigation key  until you find the baud rate you are looking for



Implies 1200 Baud communication



Implies 2400 Baud communication



Implies 4800 Baud communication

- (6) Press  key to store communication speed

- (7) Press  key to quit menu system until normal operation appears

COMMUNICATION DATA LENGTH SETTING

This parameter gives the number of bits in a communication byte. With 7 bits communication 128 different characters can be coded. On the other hand 256 different characters can be coded with 8 bits communication.

- (1) Press the navigation  key until 'Communication' menu appears



- (2) Press  key to confirm the menu

- (3) Press the navigation  key until 'Communication Data Length' menu appears



- (4) Press  key to confirm the menu

- (5) Scroll with the navigation key  until you find the communication data length you are looking for



Implies 7 bits communication



Implies 8 bits communication

- (6) Press  key to store communication data length setting

- (7) Press  key to quit menu system until normal operation appears

Note: The ASCII code for character 'A' is hexadecimal 41;
This is shown as:

	<u>7. 6. 5. 4. 3. 2. 1. 0.</u>
7 bit	x 1 0 0 0 0 0 1
8 bit	0 1 0 0 0 0 0 1

Example data stream (mod1, 8 bits and decimal point included communication):

Display
+1234

	'+'	'1'	'2'	'3'	'4'	CR
Hex	2B	31	32	33	34	0D

+123.4

	'+'	'1'	'2'	'3.'	'4'	CR
Hex	2B	31	32	B3	34	0D

-12.34

	'-'	'1'	'2.'	'3'	'4'	CR
Hex	2D	31	B2	33	34	0D

If there is a decimal point on the display, then the corresponding digit is sent with hex80 added to the ASCII value.

<u>Character</u>	<u>HEX</u>		<u>Character</u>	<u>HEX</u>	
0.	B0	(30+80)	5.	B5	(35+80)
1.	B1	(31+80)	6.	B6	(36+80)
2.	B2	(32+80)	7.	B7	(37+80)
3.	B3	(33+80)	8.	B8	(38+80)
4.	B4	(34+80)	9.	B9	(39+80)

Example data stream for mod3 (addressed communication):

If address (scale identity number) is set as 65 (41h), the indicator will send the weight data after receiving the following data.

	(Wake-up)	Address
HEX	FFh	41h

If the address is set to 0 then the indicator will send the weight data after receiving any character from the serial receive line. The address may take any value from 0 to 255.

When more than one SMART indicator is connected to the same transmission line, then the devices should have RS 485 communication hardware and all should have unique addresses.

CONNECTIONS and HARDWARE SELECTIONS

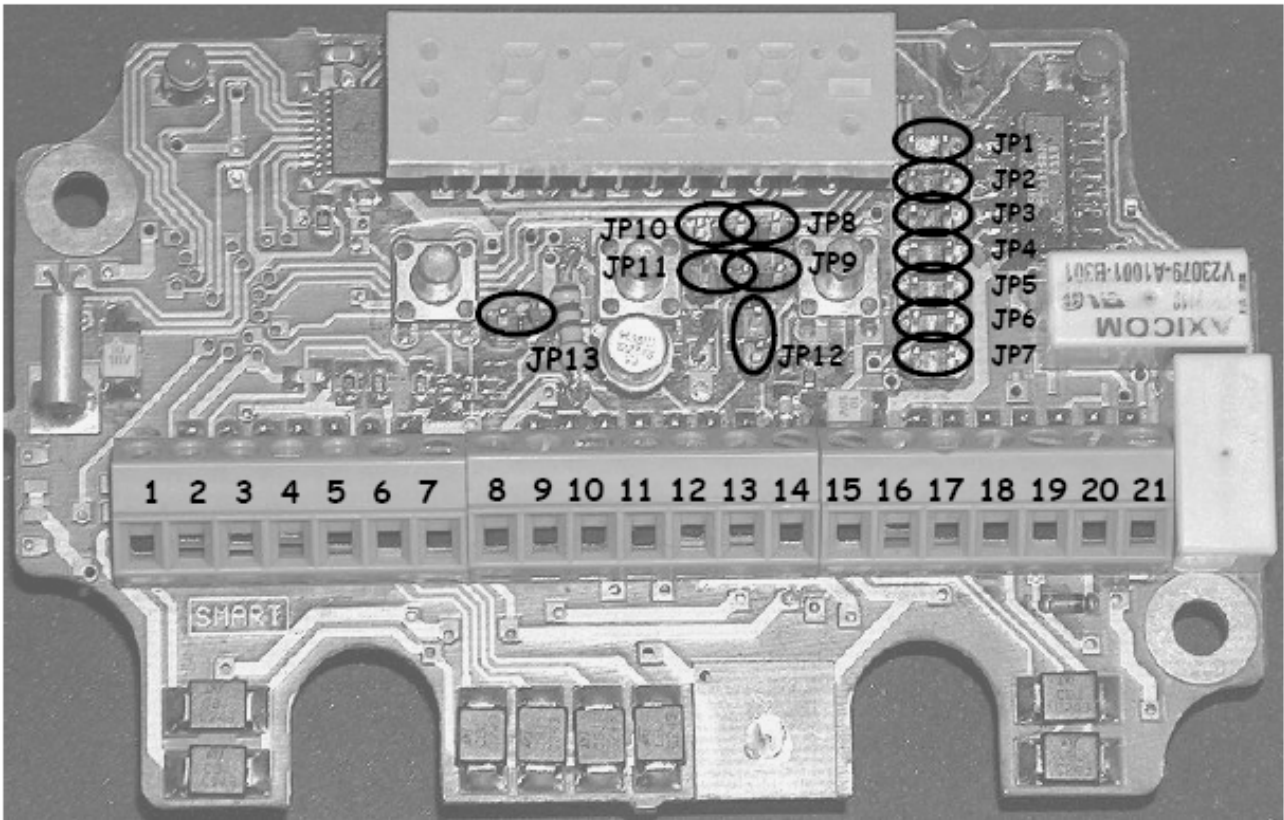

CALIBRATION KEY (jp13)

To change display settings and to perform calibration, calibration key (jp13) must be short-circuited.

All settings can be monitored but changes are not saved on 'display' menu although jp13 is open circuited. Attempting to save settings will result with 'er50' error code

To attempt to select/confirm on 'calibration' menu, while jp13 is open circuited, will result with 'er50' error code

All communication and analog output hardware selections are done by means of open-circuiting or short-circuiting the specified jp connections.

SERIAL COMMUNICATION hardware selection

RS485 communication mode: jp1 and jp2 must be short circuited; jp6 and jp7 must be open circuited

RS232 communication mode: jp6 and jp7 must be short circuited; jp1 and jp2 must be open circuited

ANALOG OUTPUT hardware selection

0-5V analog output mode: jp8 and jp9 must be short circuited; jp10, jp11 and jp12 must be open circuited

0-5V analog output connection

On the printed circuit board of the indicator, the connections are shown below assigning the leftmost terminal with terminal #1.

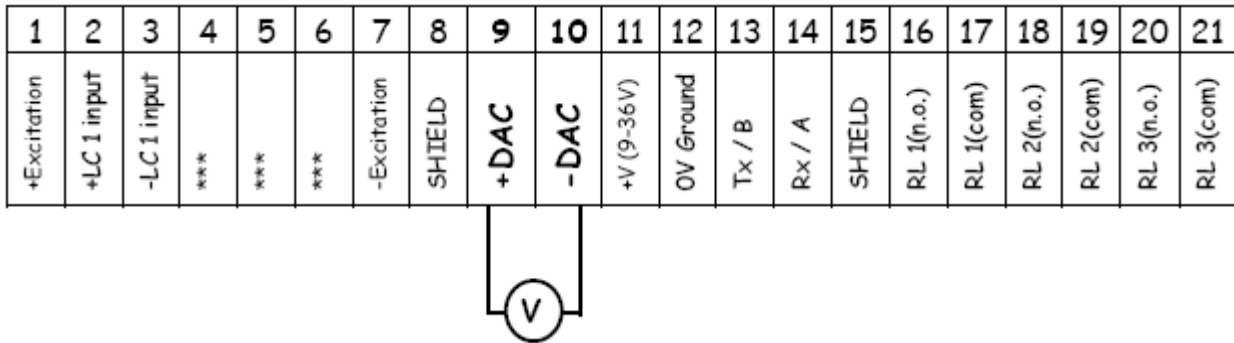

0-20mA analog output mode: jp10, jp11 and jp12 must be short circuited; jp8 and jp9 must be open circuited

0-20mA analog output connection

On the printed circuit board of the indicator, the connections are shown below assigning the leftmost terminal with terminal #1

Another power supply is required for analog current output. The current flow direction is as shown in the following figure

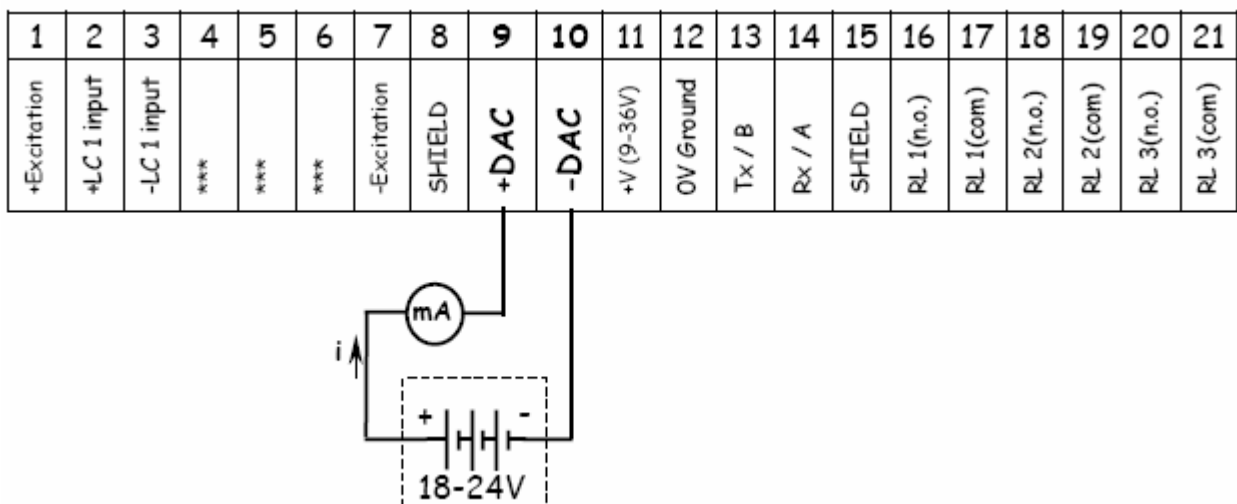

The hardwares specified above are given below in a tabulated form showing only short circuits.

	RS232	RS485
0-5V	jp6, jp7, jp8, jp9	jp1, jp2, jp8, jp9
0-20mA	jp6, jp7, jp10, jp11, jp12	jp1, jp2, jp10, jp11, jp12

ATTENTION: Any other modification on the system board (short circuits, open circuits or component modifications) rather than the specified ones will result malfunctioning and/or permanent damage on the indicator and out of guarantee.

ERROR CODES

SMART indicators may generate error codes during weight measurement and/or after wrong settings. These codes and their probable reasons are as follows:

Error 01: Display is over range
Capacity is more than $MAX+ (9*e)$



Error 02: Display is under range
Capacity is less than $-MAX- (9*e)$



Error 03: The display value cannot be zeroed
Zero calibration is needed



Error 19: Calibration error
Load value could not be '0000'



Error 50: No permission for calibration
Authorization is needed for calibration
For further information please read
'Connection and Hardware selections'
section

